

Synchronous Tilt Control

Backrest and seat of chair recline in a synchronized 2-to-1 ratio. The back of the chair moves faster than the seat which provides a greater angle between your torso and thighs adding comfort and encourages dynamic movement.

Pneumatic Lift

Raise or lower seat of chair to minimize pressure placed under thighs. At the correct seat height, feet should rest flat on the floor. To ensure smooth operations, raise and lower your seat monthly.

To raise chair, pull lever up while lifting body off seat. To lower chair, stay seated and pull lever up.

Tension Control

Increase or decrease tension of chair's tilt to match your body weight. Proper tension should allow you to lean back easily while providing balanced support when reclining.

Turn knob counter clockwise to increase tension.
Turn knob clockwise to reduce tension.

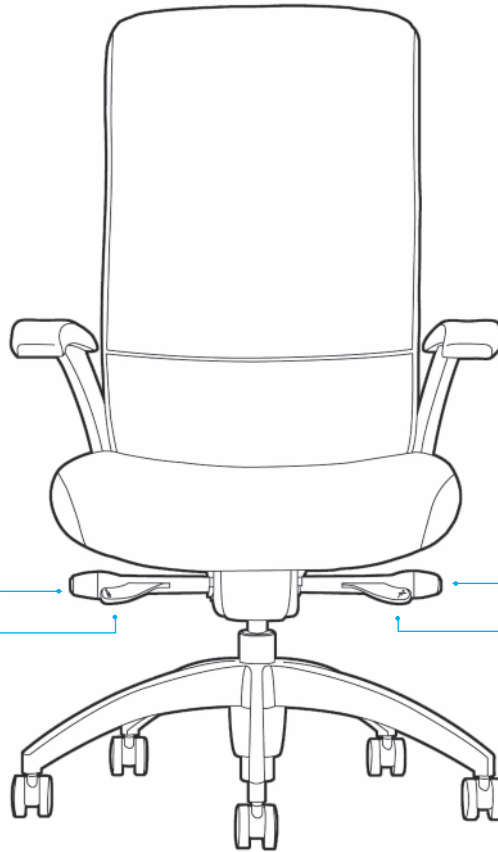

Tilt Lock

Locks tilt of chair to limit how far back chair will recline. Back can be locked in an upright position or be set to recline freely.

Push lever in to engage lock. Pull lever out to disengage lock.

Seatslide*

Adjusts seat depth to a position that best accommodates length of legs. Reduces pressure behind thighs providing proper back support and long-term comfort.

With back against chair, pull and hold lever up then slide seat forward or back. Release lever to lock.

ANSI/BIFMA Acceptance

Meets the ANSI/BIFMA X5.1-2002 general purpose office chair testing guidelines developed by the Business and Institutional Furniture Manufacturer's Association (BIFMA), and approved by the American National Standards Institute (ANSI).

*Your chair may not have all the features and adjustments shown. Please visit www.NationalOfficeFurniture.com for additional product information.

Knee Tilt Control

The chair tilts from a pivot point located near the front edge of the seat. This provides a minimal rise of the seat and allows your feet to stay flat on the floor when the chair is tilted backward.

Pneumatic Lift

Raise or lower seat of chair to minimize pressure placed under thighs. At the correct seat height, feet should rest flat on the floor. To ensure smooth operations, raise and lower your seat monthly.

To raise chair, pull lever up while lifting body off seat. To lower chair, stay seated and pull lever up.

Tilt Lock

Locks tilt of chair to limit how far back chair will recline. Back can be locked in an upright position or be set to recline freely.

Push lever in to engage lock. Pull lever out to disengage lock.

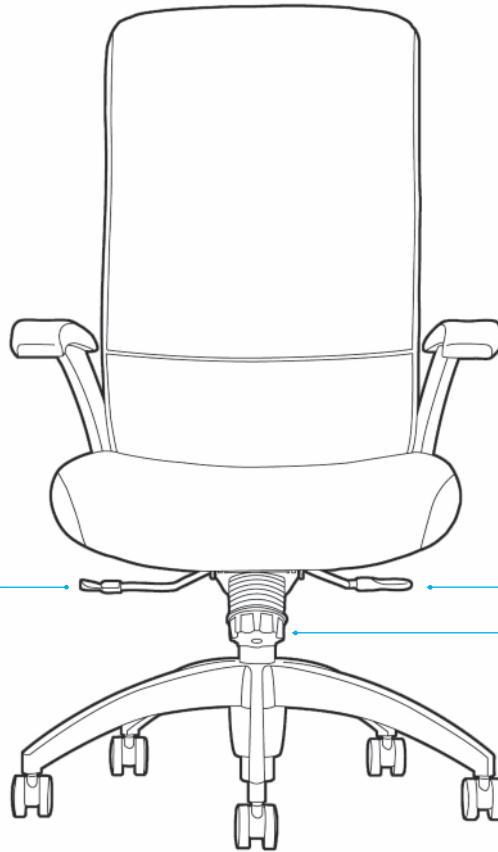

Seatslide*

Adjusts seat depth to a position that best accommodates length of legs. Reduces pressure behind thighs providing proper back support and long-term comfort.

With back against chair, pull and hold lever up then slide seat forward or back. Release lever to lock.

Tension Control

Increase or decrease tension of chair's tilt to match your body weight. Proper tension should allow you to lean back easily while providing balanced support when reclining.

Turn knob counter clockwise to increase tension. Turn knob clockwise to reduce tension.

ANSI/BIFMA Acceptance

Meets the ANSI/BIFMA X5.1-2002 general purpose office chair testing guidelines developed by the Business and Institutional Furniture Manufacturer's Association (BIFMA), and approved by the American National Standards Institute (ANSI).

*Your chair may not have all the features and adjustments shown. Please visit www.NationalOfficeFurniture.com for additional product information.