

## 1

### Base Placement Chart

Table Length	Square and Round Bases		Thick Panel, Queen Anne, Metal	
	A	B	A	B
240	30	9	28	7
234	29 1/4	9 3/4	27 1/4	7 3/4
228	28 1/2	10 1/2	26 1/2	8 1/2
222	27 3/4	11 1/4	25 3/4	9 1/4
216	27	12	25	10
210	26 1/4	12 3/4	24 1/4	10 3/4
204	25 1/2	13 1/2	23 1/2	11 1/2
198	24 3/4	14 1/4	22 3/4	12 1/4
192	24	15	22	13
186	23 1/4	15 3/4	21 1/4	13 3/4
180	22 1/2	16 1/2	20 1/2	14 1/2
174	21 3/4	17 1/4	19 3/4	15 1/4
168	21	18	19	16
162	20 1/4	18 3/4	18 1/4	16 3/4
156	19 1/2	19 1/2	17 1/2	17 1/2
150	18 3/4	20 1/4	16 3/4	18 1/4
144	24	centered	22	centered
138	23	centered	21	centered
132	22	centered	20	centered
126	21	centered	19	centered
120	20	centered	18	centered
114	19	centered	17	centered
108	18	centered	16	centered
102	17	centered	15	centered
96	24	N / A	22	N / A
90	22 1/2	N / A	20 1/2	N / A
84	21	N / A	19	N / A
78	19 1/2	N / A	17 1/2	N / A
72	18	N / A	16	N / A
66	16 1/2	N / A	14 1/2	N / A

#### Thin Panel Base

## 2

Attach L brackets to base using five (5) #10 x 3/4" panhead screws (Figure A).

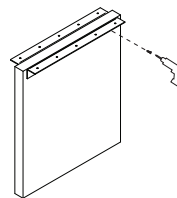

Figure A

## 3

Place the worksurfaces face down on a smooth, clean, dry surface. Per Base Placement Chart position bases. Attach base with five (5) #10 x 3/4" panhead screws per bracket (Figure B).

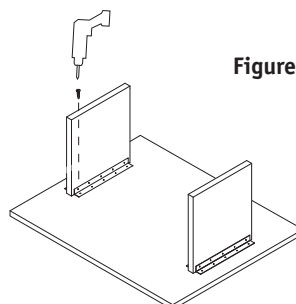
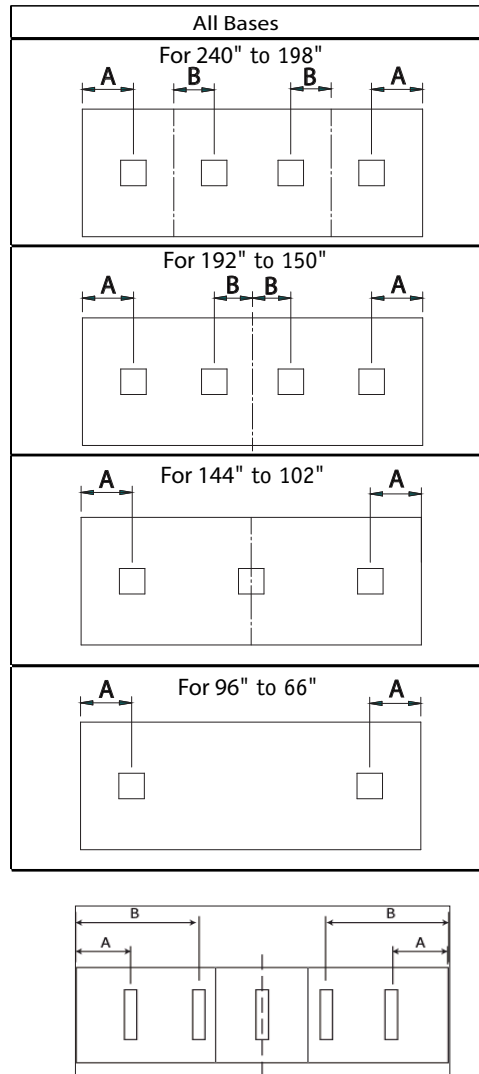

Figure B

**NOTE:** Base locations may need to shift slightly due to grommet configuration clearance.



## Conference and Training Solutions Thin Panel Base Veneer

#### Recommended Tools

- Tape Measure or Ruler
- Phillips Head Screwdriver

#### Package Contents Qty.

- 90 Deg L Brackets Per Order
- #10 x 3/4" Panhead Screws Per Order
- Mounting Brackets Per Order

# NATIONAL

Furniture with Personality®

Telephone 800.482.1717  
Fax 812.482.8800  
www.NationalOfficeFurniture.com

Part #2258947  
Rev,B

Printed in U.S.A  
© 2013 Kimball International, Inc.

## Assembly Instructions

### Thin Panel Base Veneer

**Note:** Worksurface hardware is not included with the Base. It is shown for reference only.

4

Center the mounting brackets with the edge of the worksurfaces. Attach bracket to worksurface using #10 x 3/4" panhead screws, four (4) per bracket (Figure C). **NOTE:** Place brackets after bases have been applied per Base Placement Chart to ensure no interference.

Figure C

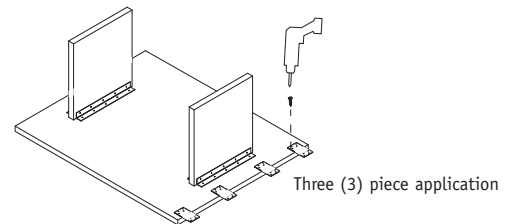
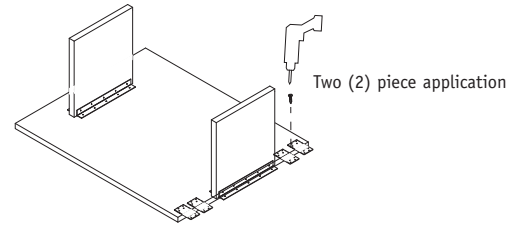

5

Locate Table in user position.  
**Two (2) Piece Worksurfaces Figure D**  
**Three (3) Piece Worksurfaces Figure E**  
Align and level worksurfaces to ensure there are no gaps or cracks. Attach mounting brackets using #10 x 3/4" panhead screws, four (4) per bracket.

Figure D

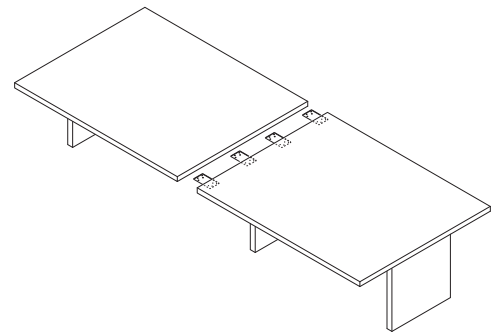

Figure E

