

Note: For better clarity, this Instruction does not always show the undersurface pedestal or other undersurface components.

1

In the desired location, place 3" wide masking tape where the end support base intersects with the lower unit. Using a pencil mark the locations of the ends and sides of each end support base. Base should be 4" off the back edge of the worksurface (Figure B).

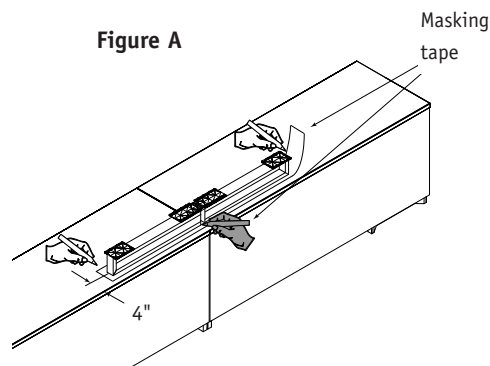

2

Using a tape measure and pencil mark the locations shown in (Figure B). For boring holes for four (4) 1/4-20 x 2 1/2" Flat Head Machine Screws.

Figure B

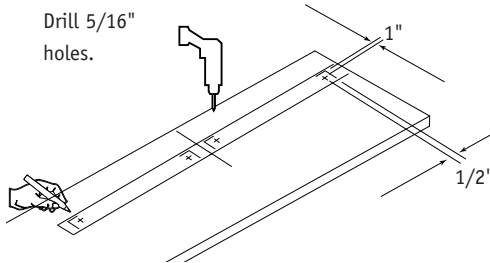

Drill four (4) 5/16" holes through the lower worksurface.

3

Place the end support bases in desired position on the underside of the upper worksurface and epicenter. Attach to the epicenter with four (4) 1/4"-20 x 1/2" bolts, attach to the worksurface with twenty four (24) #12 x 7/8" flat head screws, (Figure C). **NOTE:** Hand tighten until all components are attached.

Figure C

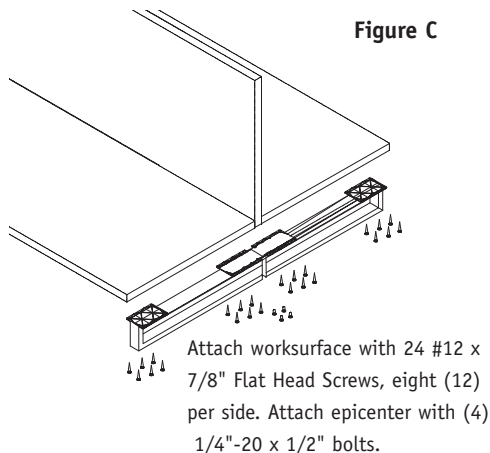

4

With the upper and lower units positioned in the desired locations, install four (4) 1/4-20 x 2 1/2" Flat Head Machine screws through the lower worksurface into the end support base (Figure D).

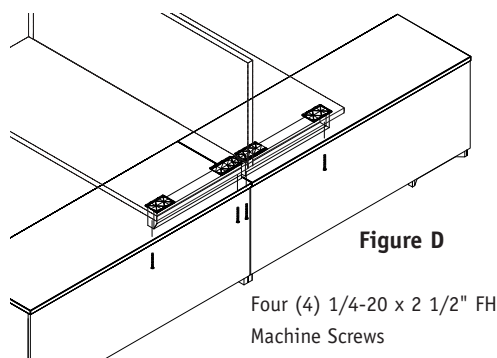

End Support Base

Recommended Tools

- Drill with 5/16" bit
- Phillips head screwdriver
- Tape Measure
- 3" wide masking tape
- Pencil

Package Contents Qty.

- End Support Base 2
- #12 x 7/8" Flat Head Screw 24
- 1/4-20 x 2 1/2" Flat Head Machine Screw 4
- 1/4-20 x 1/2" Bolt 4

NATIONAL

Furniture with Personality®

Telephone 800.482.1717
 Fax 812.482.8800
 www.NationalOfficeFurniture.com

Part #2439937
 Rev,-

Printed in U.S.A
 © 2012 Kimball International, Inc.