

Parts Included

Foot Kit:

- 2 Feet
- 2 Top Supports

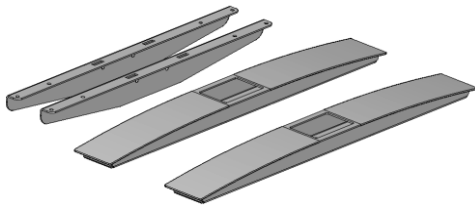

J-Rail Kit:

- 2 J-Rails
- Hex Rod to be Included on a Crank Assembly only.

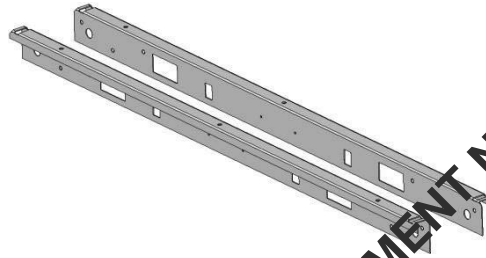

Column Kit:

- 2 Electric or Crank Columns
- 3rd Leg option for 3 leg Assembly

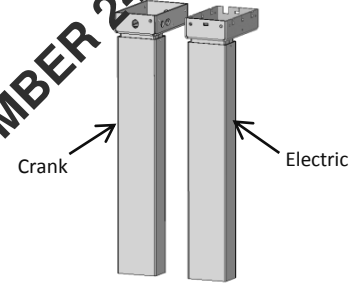

Electrical Components:

- (A) Control Switch
- (B) Control Box
- Plug Set

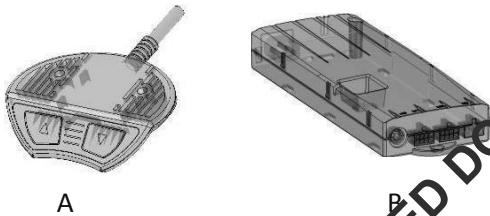

Crank Components:

- (C) Crank Handle Assembly
- (D) Hex Rod
- (E) 3" Extension For 30" Deep Top Only*

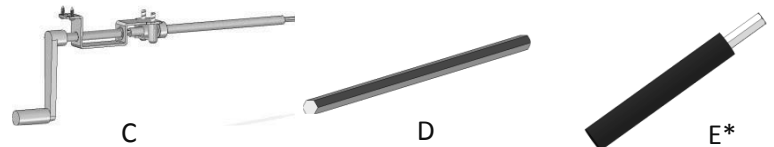

Hardware Pack:

- (F) M6x12mm Socket Head - QTY: 12 or 18
- (G) M6x12mm Flat Head - QTY: 4
- (H) M10x20mm Button Head - QTY: 4



3 Leg Table Components:

- (I) LH 90 Degree Adapter (J) RH 90 Degree Adapter
- (K) LH 120 Degree Adapter (L) RH 120 Degree Adapter
- Need a 3rd Column to match Crank or Electric and 18 total Qty. of screw (F).

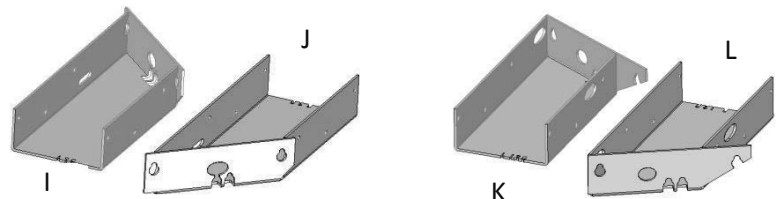

EXTERNALLY MANAGED DOCUMENT, KIMBALL DOCUMENT NUMBER 2491634

Crank Assembly Instructions

REQUIRED TOOLS:	EACH TABLE INCLUDES:
<ul style="list-style-type: none"> #2 Phillips Driver Metric Allen Wrenches 	<ul style="list-style-type: none"> Column Kit J-Rail Kit w/ Hex Rod Foot Kit w/ Top Supports

- Line up J-Rails to the appropriate Column and attach using the M6x12mm Socket head screws provided.
 - Note: The Leg Columns are marked right and left handed inside the Gear Box Case. Right hand is marked with a blue circle and left hand is marked with a black circle.

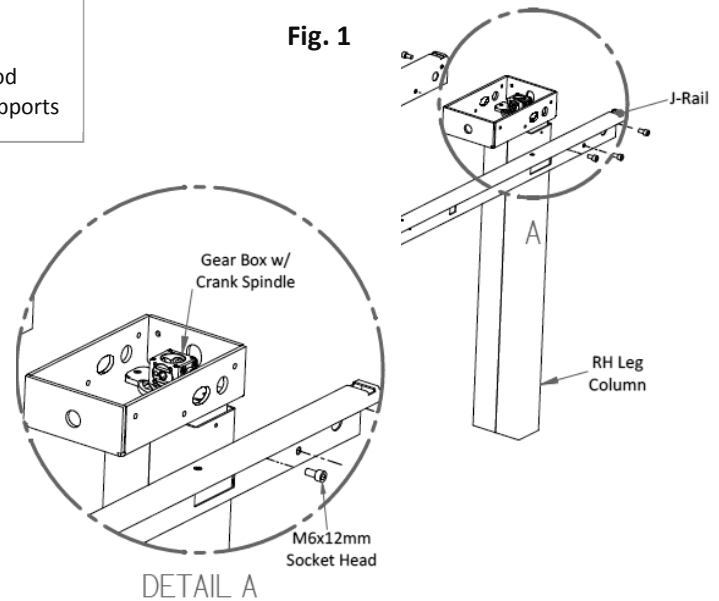

- Insert Hex Rod into the Thru Hole on either Leg Column (Fig. 2) and slide it through into the other leg. Center the Hex Rod in the assembly.
- After the Hex Rod is in place, attach the top supports to the appropriate columns with the M6x12mm Flat Head Screws. (Fig. 3)

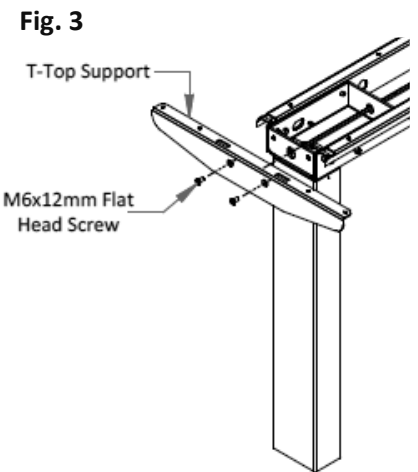
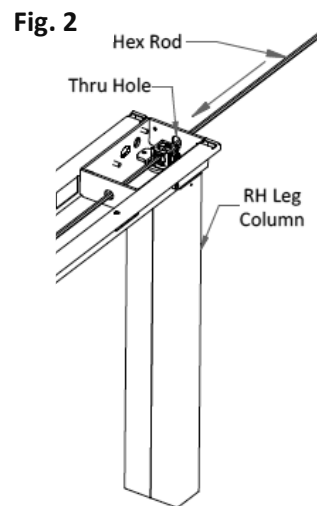

- Carefully flip the table as show in Fig. 4 and then attach the T-Feet using the M10x20mm Button Head Screws provided.

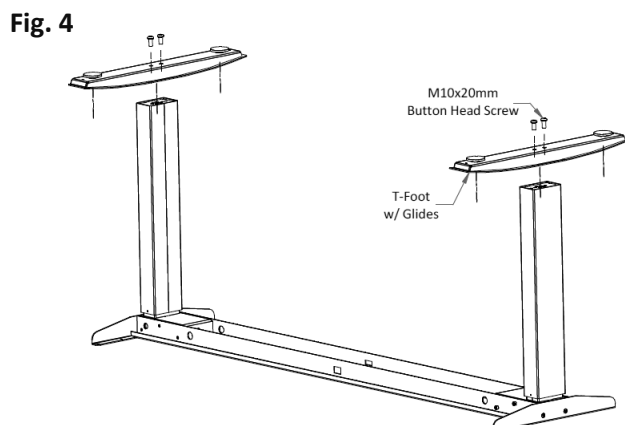

- To attach the table top to the assembly; place the top supports an appropriate distance from the front of the table top and then center onto the table top.

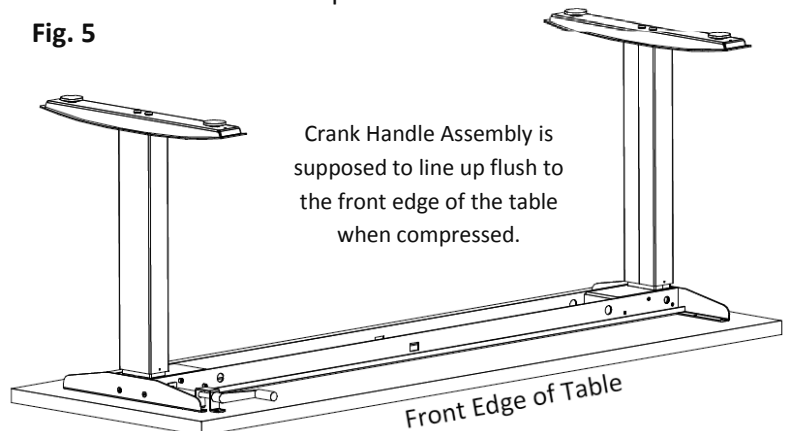

Electric Assembly Instructions

REQUIRED TOOLS:

- #2 Phillips Driver
- Metric Allen Wrenches

EACH TABLE INCLUDES:

- Column Kit
- J-Rail Kit
- Foot Kit w/ Top Supports

1. Line up J-Rails to the Columns and attach using the M6x12mm Socket head screws provided.

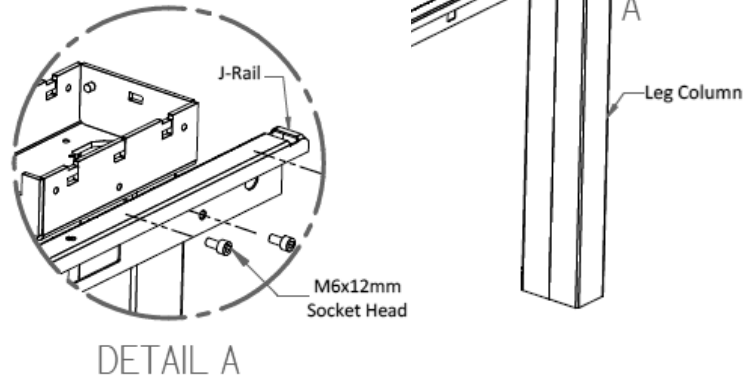

2. Attach the top support to the leg column using the M6x12mm flat head screws provided. (Fig. 2)
3. After step 2 is complete, flip the assembly over onto the bottom side of the table top.
4. Attach the feet to the columns using the M10x20mm Button Head Screws provided. While making sure they are pointing the same way as the top supports. (Fig. 3)

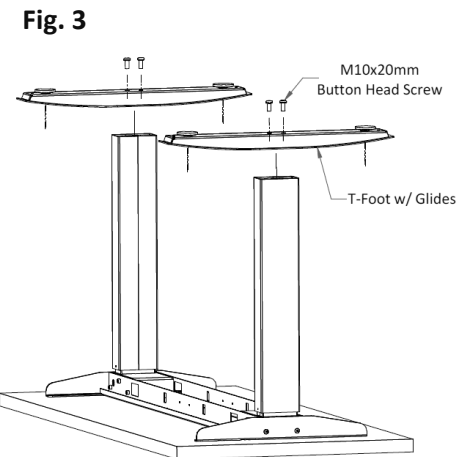
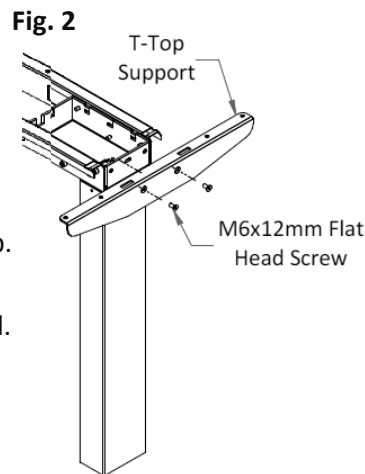

5. Below is a layout of how a proper assembly should look. (Fig. 4)

PLEASE NOTE:

- To synchronize the control and motors plug in all of the control cables, power cable, and the switch.
- Hold the down button until the unit bottoms out, you will hear a clicking sound and the columns will move slightly upward.
- If you lose power to the unit you will have to re-synchronize.

Fig. 4

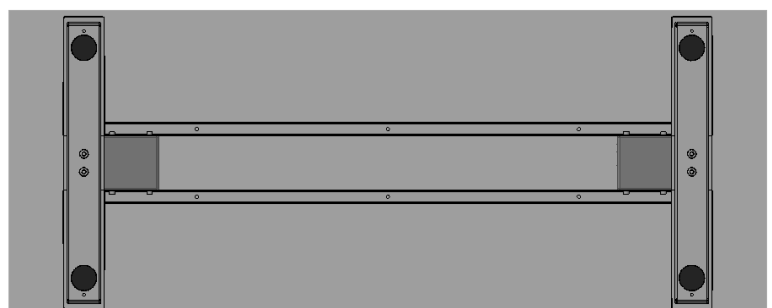

3-Leg Assembly Instructions

3 Leg Table Components:

- (I) LH 90 Degree Adapter (J) RH 90 Degree Adapter
- Need a 3rd Column to match Crank or Electric.

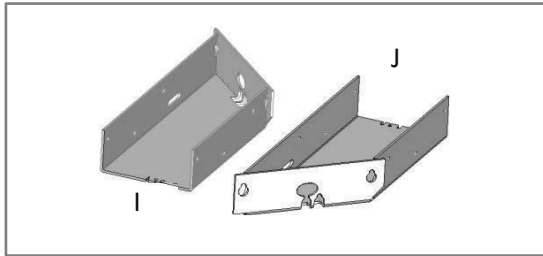
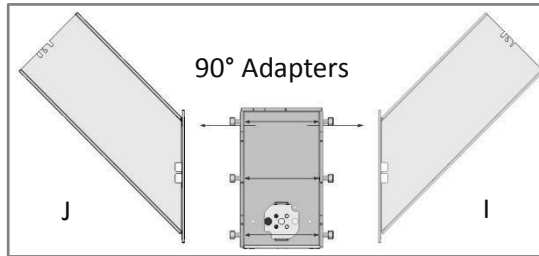

Fig. 1



1. Attach the 90° or 120° adapters to the 3rd column by first screwing the M6x12mm Socket Head screws almost all the way into the motor box, and then hang the adapter over the screws and finish driving the screws down. (Fig. 1)
2. Just like with a 2 leg assembly, line up the J-Rails to the assembly, except this time you will attach them to the 90° or 120° adapters as shown. (Fig. 2)
3. The 3 Leg Assembly should lay out as shown. (Fig. 3)
The example shown is a 90° 3-Leg Table with T-Feet.

Fig. 2

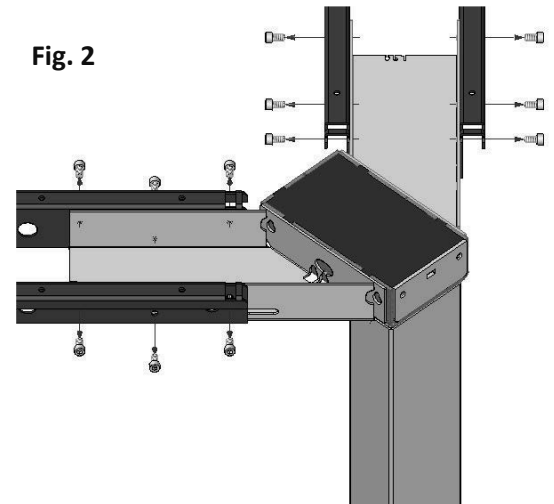
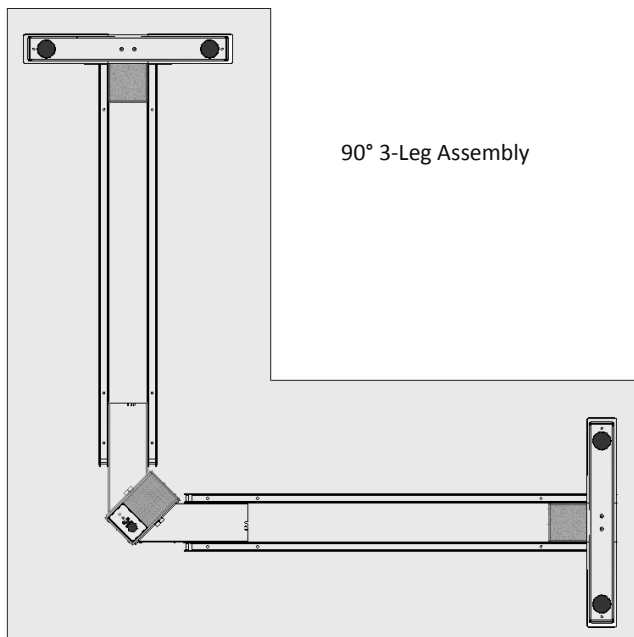

Fig. 3



90° 3-Leg Assembly

3rd Leg Top Support Instructions

1. Attach the RH and LH adapters to the side of the motor box on the column with the M6x12mm Socket Head Screws provided. (Fig. A)
2. After the adapters are fastened to the sides of the motor box, place the top support provided on the outside of the column so that the 2 holes line up with the ones on the back of the motor box.
3. Fasten the top support with the M6x12mm Flat Head Screws provided. (Fig. B)
4. Use the wood screws provided to attach the top support to the work surface. (Fig. C)

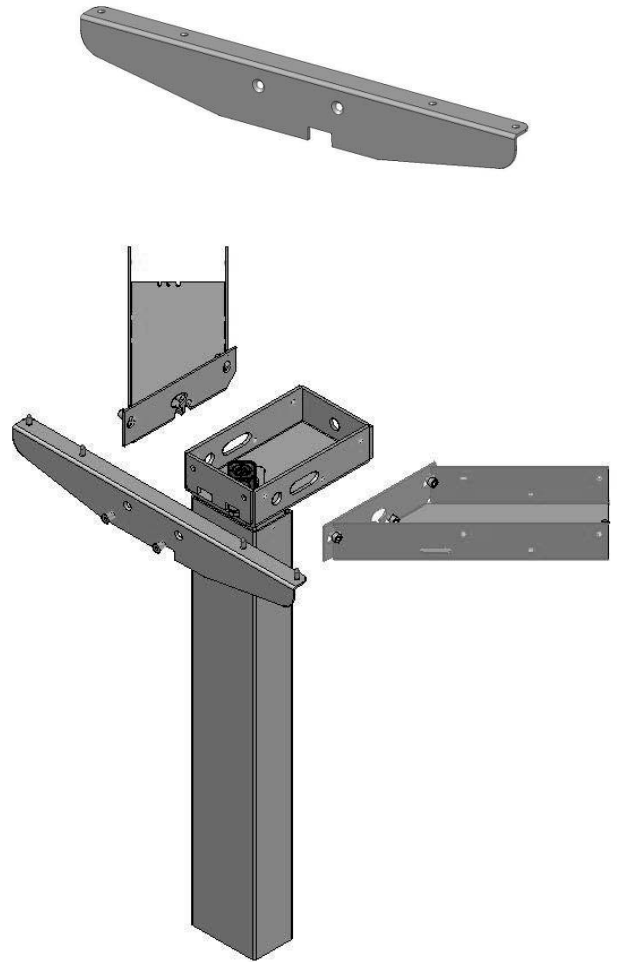

Fig. A



Fig. B



Fig. C

