

## Assembly Instruction

### WaveWorks False Pedestal

- 1** The false pedestal is used to support the end of a worksurface when a pedestal is not used. A component back panel and worksurface is required to fully assemble the false pedestal. Right false pedestal shown (Figure A). Left false pedestal shown (Figure B).

Note: Grommet options are shown (Figure A & B).

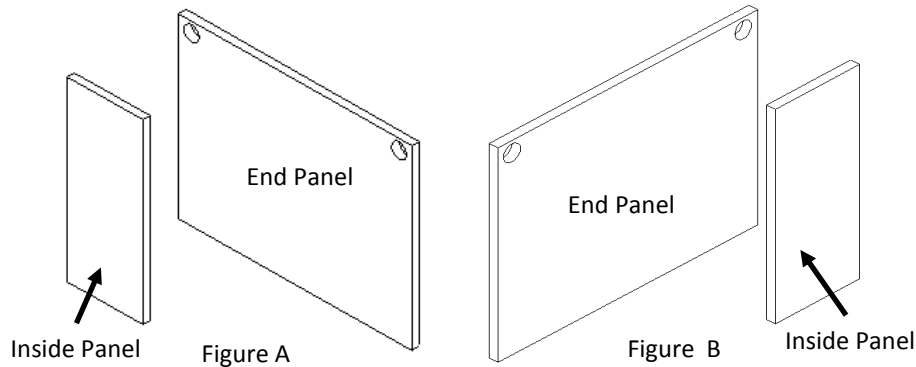

### Package Contents

	Qty
End Panel	1
Inside Panel	1
#8 x 5/8" screws	22
#8 x 1" screws	6
L Bracket	14
Adjustable Glide	4

- 2** Locate the end panel (5/64") from the end of the worksurface and (1/16") from the back of the worksurface. (Figure C).

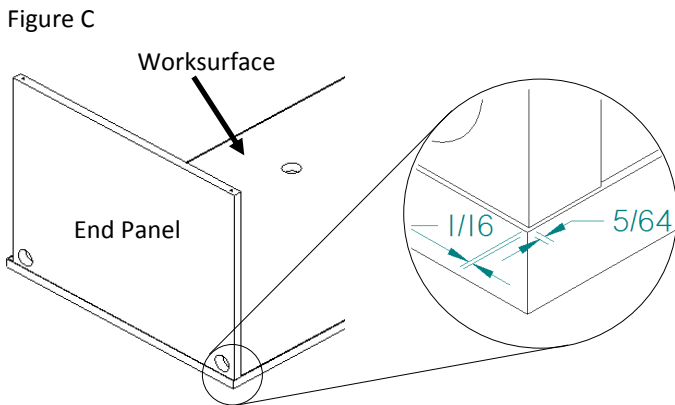

- 3** Fasten in position using three (3) evenly spaced L brackets, three (3) #8 x 5/8" screws, and three (3) #8 x 1" screw to attach modular end panel to the worksurface (Figure D).

Note: Use three (3) #8 x 1" screw to attach L bracket to the worksurface (Figure D).

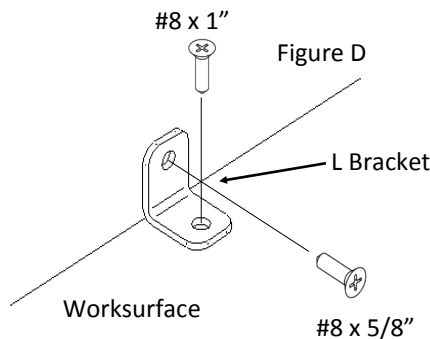

# NATIONAL

Furniture with Personality™

Telephone 800.482.1717  
 Fax 812.482.8800  
[www.NationalOfficeFurniture.com](http://www.NationalOfficeFurniture.com)

Part # 2713836  
 Rev. -

Printed in U.S.A.  
 © 2014 Kimball International, Inc.

Proper product installation, in accordance with these instructions, is the responsibility of the installing agent. If you have any questions concerning these instructions, please call National Customer Service 800.482.1717.

## Assembly Instruction

### WaveWorks False Pedestal

- 4** Using a framing square, make sure the end panel is perpendicular to the worksurface. Locate the back panel ( $5/64$ " ) from the outside edge of the end panel (Figure E).

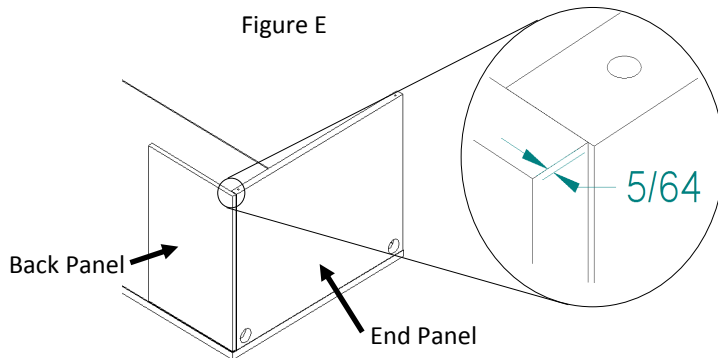

- 5** Attach the back panel to the worksurface and end panel using five (5) L brackets, nine (9) #8 x  $5/8$ " Screws, and one (1) #8 x 1" Screw (Figure F).

Note: Use one (1) #8 x 1" Screw to attach L bracket to worksurface (Figure F).

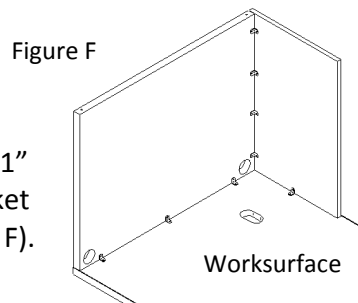

- 6** Using a framing square, make sure the back panel is perpendicular to the worksurface and end panel. Locate the inside panel ( $5/64$ " ) from the outside edge of the end panel (Figure G).

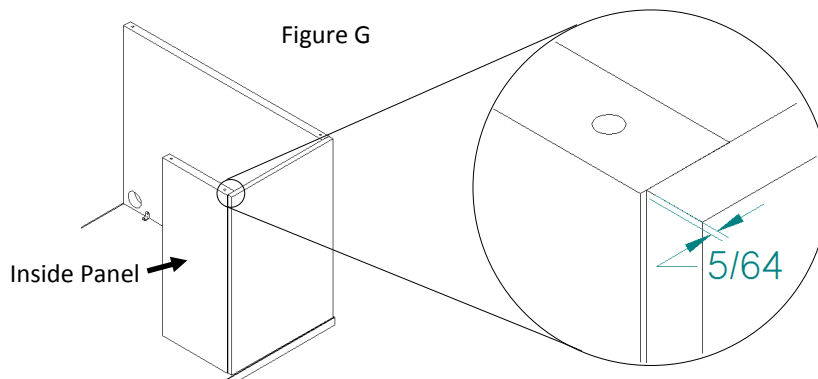

Proper product installation, in accordance with these instructions, is the responsibility of the installing agent. If you have any questions concerning these instructions, please call National Customer Service 800.482.1717.

# NATIONAL

Furniture with Personality<sup>®</sup>

Telephone 800.482.1717  
Fax 812.482.8800  
[www.NationalOfficeFurniture.com](http://www.NationalOfficeFurniture.com)

Part # 2713836  
Rev. -

Printed in U.S.A.  
© 2014 Kimball International, Inc.

## Assembly Instruction

### WaveWorks False Pedestal

- 7** Attach the inside panel to the worksurface and back panel using six (6) L brackets, ten (10) #8 x 5/8" screws, and two (2) #8 x 1" screws (Figure H).

Note: Use two (2) #8 x 1" Screws to attach L brackets to worksurface (Figure F).

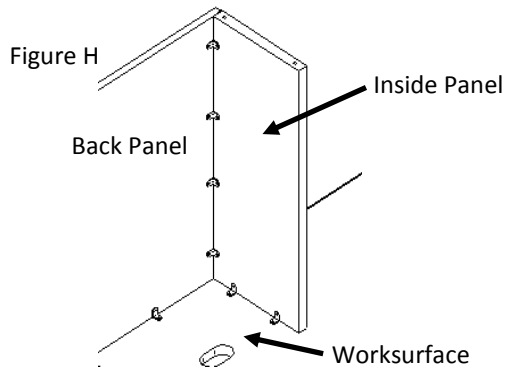

- 8** Screw the four (4) adjustable glide leveling feet into the threaded holes located on the bottom of the inside and end panel (Figure J).

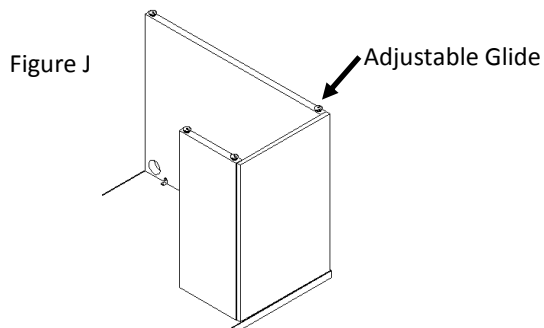

**NATIONAL**

Furniture with Personality®

Telephone 800.482.1717  
Fax 812.482.8800  
[www.NationalOfficeFurniture.com](http://www.NationalOfficeFurniture.com)

Part # 2713836  
Rev. -

Printed in U.S.A.  
© 2014 Kimball International, Inc.

Proper product installation, in accordance with these instructions, is the responsibility of the installing agent. If you have any questions concerning these instructions, please call National Customer Service 800.482.1717.