

Assembly Instruction

Note: This instruction will cover the assembly of hardwire fixed height center beams.

- 1** With the center beam upside down. Remove both hardwire junction boxes from the center beam as shown in **Figure A**.

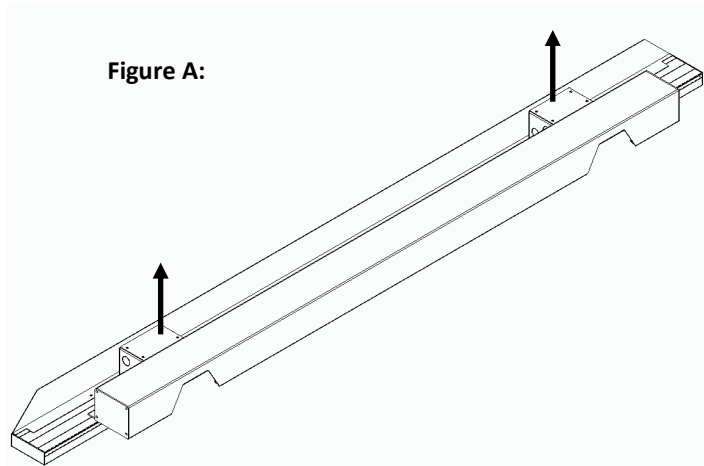

- 2** Remove the four screws securing one U-Channel to the center beam as shown in **Figure B**.

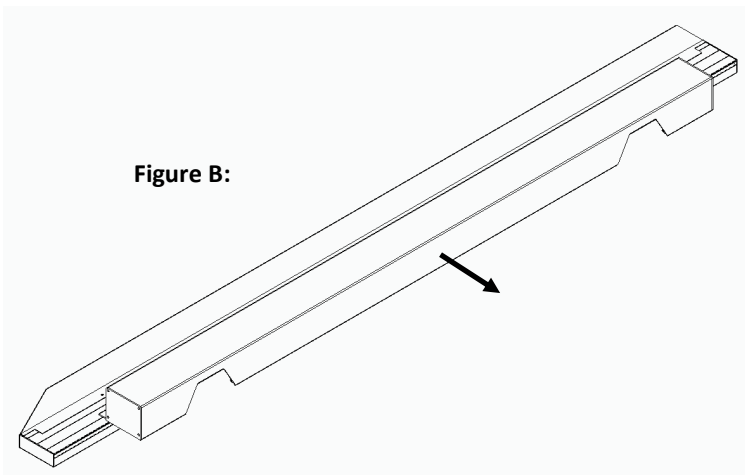

- 3** Have a licensed electrician wire and install the junction boxes on the center beam in the desired configuration. Re-install the U-Channel and junction box / cover in reverse order of steps 1 & 2.

Alloy
Fixed Height
Single Center-
Beam Hardwire

Package Contents

| Hardware | Qty |
|--------------------|-----|
| #8 x 1 Wood Screw | 16 |
| Self Driving Screw | 4 |

Tools Required

Screw Driver
#2 Phillips Driver
#3 Phillips Driver

NATIONAL

Furniture with Personality™

Telephone 800.482.1717
Fax 812.482.8800
www.NationalOfficeFurniture.com

Part # 3057149
Rev. -

Printed in U.S.A
© 2014 Kimball International, Inc.

Proper product installation, in accordance with these instructions, is the responsibility of the installing agent. If you have any questions concerning these instructions, please call National Customer Service 800.482.1717.

Assembly Instruction

- 4** From the bottom of the beam align the two inside v grooves with the four holes in the flat mounting brackets as shown in **Figure C**. Using the four provided self-drilling screws secure the beam to the brackets. Verify the beam is and brackets as aligned as shown below. It is recommended to use a clamp and pads when fastening the beam to help prevent misalignment.

Figure C:

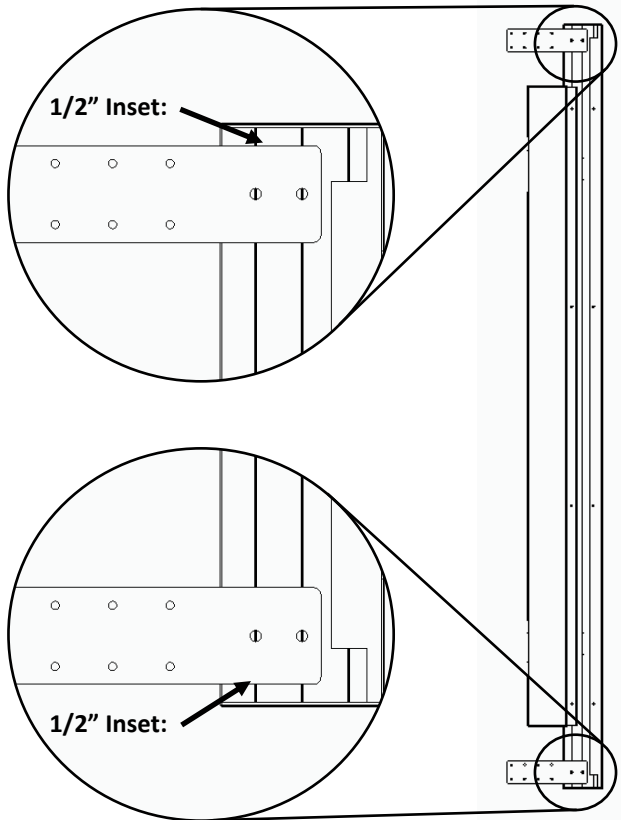

NATIONAL

Furniture with Personality[®]

Telephone 800.482.1717
Fax 812.482.8800
www.NationalOfficeFurniture.com

Part # 3057149
Rev. -

Printed in U.S.A.
© 2014 Kimball International, Inc.

Proper product installation, in accordance with these instructions, is the responsibility of the installing agent. If you have any questions concerning these instructions, please call National Customer Service 800.482.1717.

Assembly Instruction

- 5 Align the beam assembly to the underside of the worksurface. Use the 16 provided wood screws to secure the assembly as shown in **Figure D**. Attach the table frame to the worksurface.

Figure D:

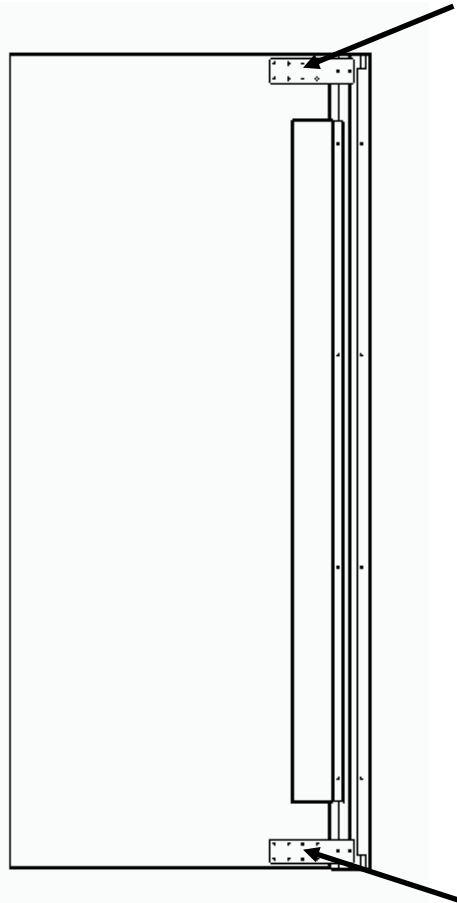

Alloy
Fixed Height
Single Center-
Beam Hardwire

NATIONAL

Furniture with Personality®

Telephone 800.482.1717
Fax 812.482.8800
www.NationalOfficeFurniture.com

Part # 3057149
Rev. -

Printed in U.S.A.
© 2014 Kimball International, Inc.

Proper product installation, in accordance with these instructions, is the responsibility of the installing agent. If you have any questions concerning these instructions, please call National Customer Service 800.482.1717.