

Assembly Instruction

1 READ ALL DIRECTIONS BEFORE BEGINNING ASSEMBLY. IT IS ADVISABLE TO SAVE ASSEMBLY OF THESE TRAY UNITS UNTIL ALL OTHER FRAME AND BOX MODULES HAVE BEEN BUILT AND POSITIONED IN THEIR FINAL INSTALLED LOCATION. THERE ARE DIFFERENT STEPS TO FOLLOW IF THE TRAY MODULE IS TO BE POSITIONED ABOVE A FRONT OPEN BOX OR PASS THRU MODULE VS THE STANDARD INSTALLATION IN ALL OTHER SCENARIOS.

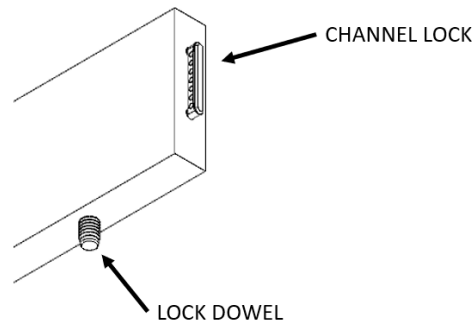

FIGURE A

THIS MODULE IS ASSEMBLED WITH A HIDDEN FASTENER HARDWARE SYSTEM THAT COMES PREINSTALLED. THERE ARE TWO TYPES IN THIS ASSEMBLY, CHANNEL LOCKS AND LOCK DOWELS (**FIGURE A**). IF PANELS APPEAR TO BE MISSING FASTENERS OR THEY ARE DAMAGED, CONTACT CUSTOMER SERVICE FOR REPLACEMENTS. DO NOT ASSEMBLY THIS UNIT WITHOUT ALL HARDWARE INSTALLED AS MODULE IS **PERMANENT** AFTER ASSEMBLY.

2 TAKE THE BOTTOM PANEL (**FIGURE B**) AND LAYOUT ONTO WORK SURFACE. PANEL SHOULD HAVE FOUR CHANNEL LOCKS TOTAL, TWO PER SIDE.

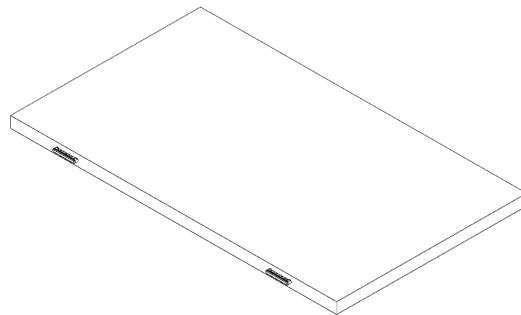

FIGURE B

3 LOCATE THE FRONT AND BACK PANELS. THEY'RE THE TWO LONGER PANELS (**FIGURE C**) OF THE FOUR INCH WIDE PANELS.

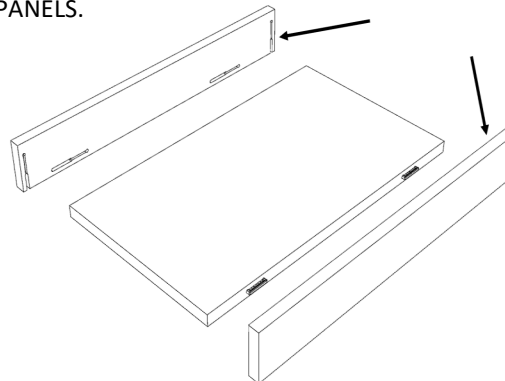

FIGURE C

LOCHLYN MODULE TRAY

TOOLS REQUIRED

RUBBER Mallet

FLAT HEAD SCREW DRIVER/PRY TOOL

DRILL DRIVER W/ 5/16 OR 8MM BIT

NATIONAL

Furniture with Personality®

Telephone 800.482.1717
Fax 812.482.8800
www.NationalOfficeFurniture.com

3249015
Rev. -

Proper product installation, in accordance with these instructions, is the responsibility of the installing agent. If you have any questions concerning these instructions, please call National Customer Service 800.482.1717.

Assembly Instruction

LOCHLYN MODULE TRAY

4 NOTE THE ROUTED PROFILES (**FIGURE D**) ON THE FRONT PANEL AND THE DIRECTION OF THE SMALLER ROUT COMPARED TO THE CLEARANCE SLOT. THE SMALLER ROUT IS THE CAPTURE PROFILE THAT WILL HOLD AND POSITION THE CHANNEL LOCK. FIT THE ROUTED PROFILES OVER THE CHANNEL LOCKS (**FIGURE E**) ON THE BOTTOM PANEL AND SLIDE OVER TO LOCK IN THE PANEL. THE FRONT PANEL WILL BE SYMMETRIC ABOUT THE BOTTOM PANEL IF INSTALLED CORRECTLY (**FIGURE F**).

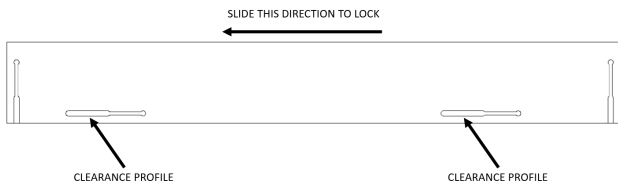

FIGURE D

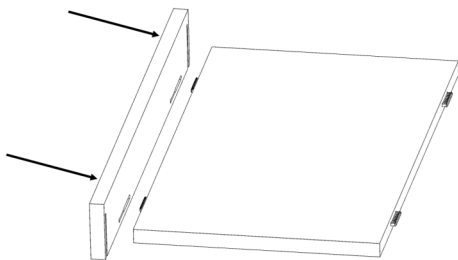

FIGURE E

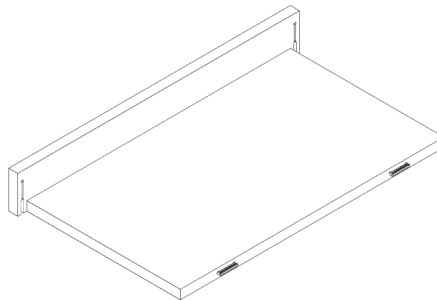

FIGURE F

5 REPEAT STEP 4 WITH THE BACK PANEL (**FIGURE G**).

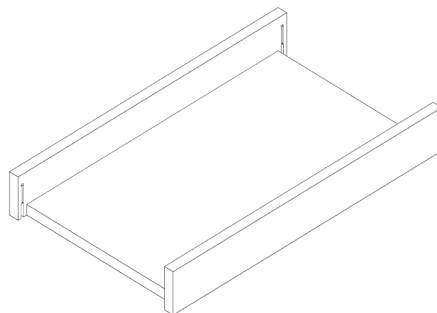

FIGURE G

6 LOCATE END PANELS (**FIGURE H**) AND SLIDE THESE INTO THE FRONT AND BACK PANEL PROFILES. ENSURE THE CHANNEL LOCKS FEED INTO THE PROFILES AND THE LOCK DOWELS ARE FACING DOWN FLUSH WITH THE BOTTOM PANEL (**FIGURE I**).

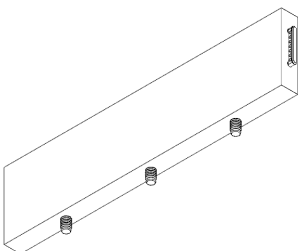

FIGURE H

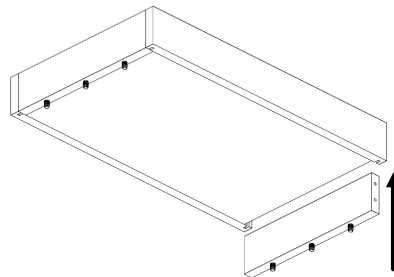

FIGURE I

Proper product installation, in accordance with these instructions, is the responsibility of the installing agent. If you have any questions concerning these instructions, please call National Customer Service 800.482.1717.

NATIONAL

Furniture with Personality®

Telephone 800.482.1717
Fax 812.482.8800
www.NationalOfficeFurniture.com

3249015
Rev. -

Assembly Instruction

LOCHLYN MODULE TRAY

CAUTION! STEPS 7-11

7 THE STEPS DESCRIBED BELOW ARE TO BE FOLLOWED **ONLY** IF THE TRAY MODULE IS TO BE POSITIONED DIRECTLY ABOVE A **FRONT OPEN OR PASS THRU MODULE** (FIGURE J).

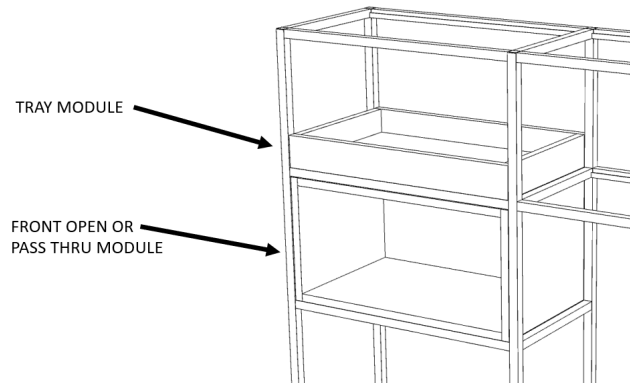

FIGURE J

8 WITH A FLAT HEAD SCREWDRIVER OR PRYBAR LIFT AND REMOVE THE TOP COVER PANEL OF THE MODULE DIRECTLY BELOW THE TRAY (FIGURE K). TAKE CARE TO NOT DAMAGE THE FINISH WITH THE PRY BAR. THIS PANEL WILL SERVE AS THE ANCHOR PANEL FOR THE TRAY RATHER THAN THE ONE THAT'S INCLUDED WITH THE TRAY. THE ROUTED CUTS ON THE BOTTOM OF THIS PANEL ARE REQUIRED TO PROVIDE CLEARANCE TO THE BRACKETS THAT MOUNT THE UNIT BELOW THE TRAY.

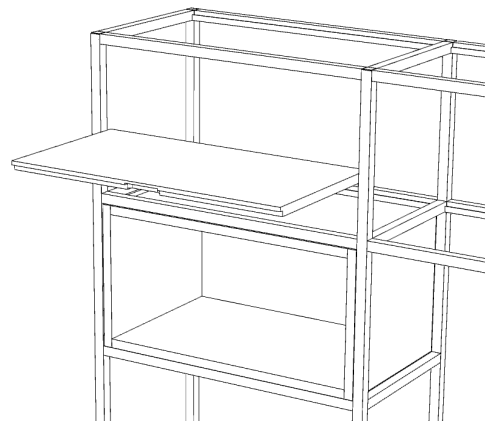

FIGURE K

9 THE BOTTOM OF THE COVER PANEL HAS SIX PILOT HOLES IN IT THAT SERVE AS STARTS THAT ALIGN WITH THE LOCK DOWELS ON THE TRAY UNIT. TAKE A DRILL WITH A 5/16" (OR 8MM) BIT AND DRILL THRU ALL SIX STARTS IN THE PANEL (FIGURE L).

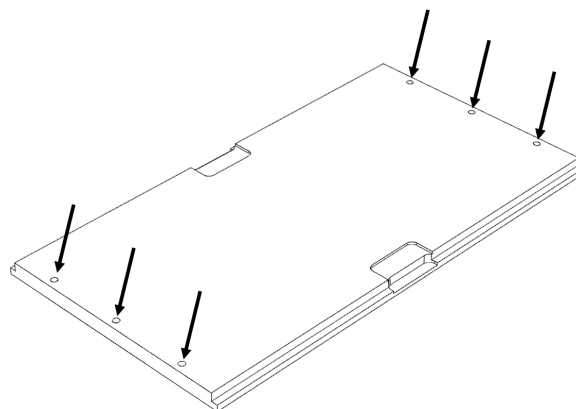

FIGURE L

NATIONAL

Furniture with Personality™

Telephone 800.482.1717
Fax 812.482.8800
www.NationalOfficeFurniture.com

3249015
Rev. -

Proper product installation, in accordance with these instructions, is the responsibility of the installing agent. If you have any questions concerning these instructions, please call National Customer Service 800.482.1717.

Assembly Instruction

10 FLIP THE COVER PANEL OVER TO ENSURE THE TOP FACE IS ORIENTED UPWARDS. POSITION THE TRAY ASSEMBLY LOCK DOWELS OVER THE DRILLED HOLES IN THE PANEL AND PRESS DOWN TO ENGAGE THEM (**FIGURE M**). A RUBBER Mallet IS USEFUL TO FINISH ASSEMBLY AND ENSURE THE LOCK DOWELS ARE BOTTOMED OUT. TAKE CARE TO NOT DAMAGE THE TRAY WITH THE Mallet. THE TRAY WILL BE A PERMANENT ASSEMBLY AT THIS POINT.

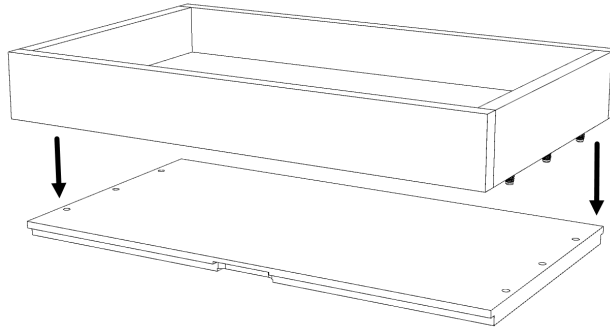

FIGURE M

11 SLIDE THE TRAY INTO THE FRAME (**FIGURE N**) AND POSITION IN ITS INSTALLED LOCATION (**FIGURE O**). THE COVER PANEL WILL SIT DOWN IN THE FRAME AND THE FRONT PANELS WILL REST ON THE FRAME HORIZONTAL CROSS MEMBERS. INSTALLATION IS COMPLETE FOR THIS SCENARIO.

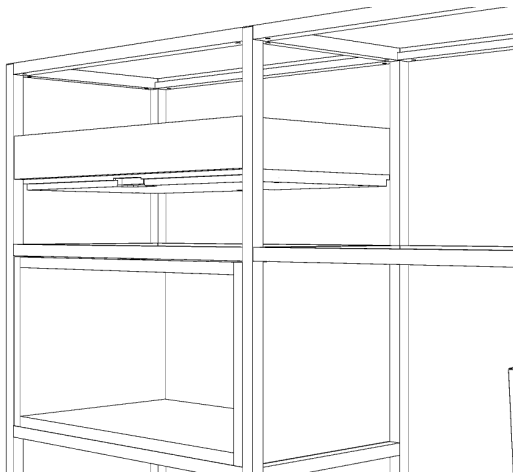

FIGURE N

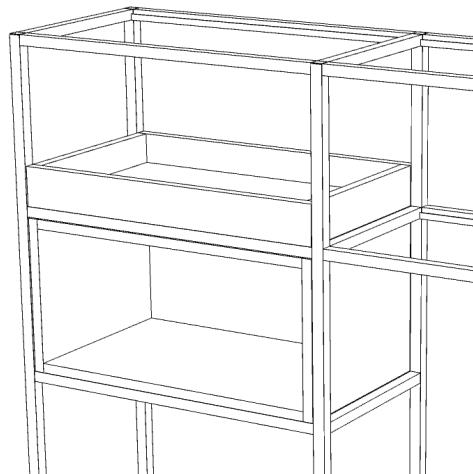

FIGURE O

LOCHLYN MODULE TRAY

NATIONAL

Furniture with Personality®

Telephone 800.482.1717
Fax 812.482.8800
www.NationalOfficeFurniture.com

3249015
Rev. -

Proper product installation, in accordance with these instructions, is the responsibility of the installing agent. If you have any questions concerning these instructions, please call National Customer Service 800.482.1717.

Assembly Instruction

LOCHLYN MODULE TRAY

CAUTION! STEPS 12-14

12 THE STEPS DESCRIBED BELOW ARE TO BE FOLLOWED **ONLY** IF THE TRAY MODULE IS TO BE POSITIONED OVER TOP OF A SHELF, ANOTHER TRAY, OPEN TOP BOX, OR EMPTY FRAME MODULE (**FIGURE P**).

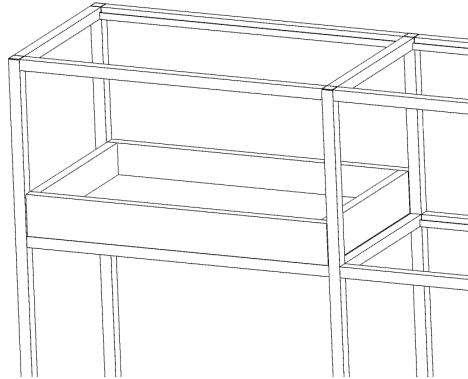

FIGURE P

13 POSITION THE TRAY ASSEMBLY LOCK DOWELS OVER THE ANCHOR PANEL AND PRESS DOWN TO ENGAGE THEM (**FIGURE Q**). A RUBBER Mallet IS USEFUL TO FINISH ASSEMBLY AND ENSURE THE LOCK DOWELS ARE BOTTOMED OUT. TAKE CARE TO NOT DAMAGE THE TRAY WITH THE Mallet. THE TRAY WILL BE A PERMANENT ASSEMBLY AT THIS POINT.

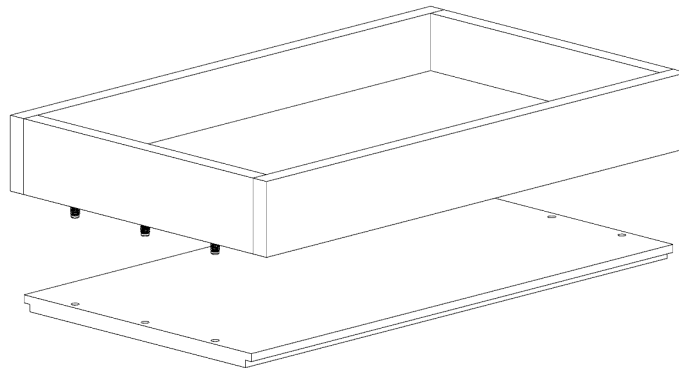

FIGURE Q

14 SLIDE THE TRAY INTO THE FRAME (**FIGURE R**) AND POSITION IN ITS INSTALLED LOCATION (**FIGURE S**). THE ANCHOR PANEL WILL SIT DOWN IN THE FRAME AND THE FRONT PANELS WILL REST ON THE FRAME HORIZONTAL CROSS MEMBERS. INSTALLATION IS COMPLETE FOR THIS SCENARIO.

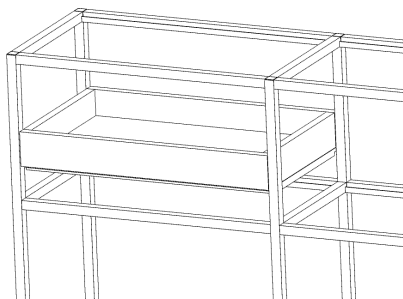

FIGURE R

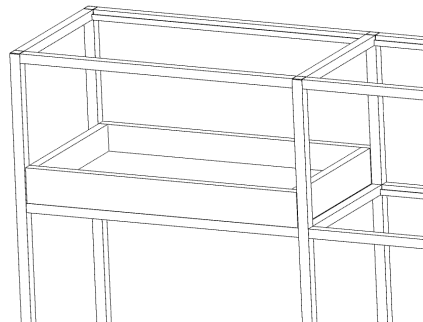

FIGURE S

NATIONAL

Furniture with Personality®

Telephone 800.482.1717
Fax 812.482.8800
www.NationalOfficeFurniture.com

3249015
Rev. -

Proper product installation, in accordance with these instructions, is the responsibility of the installing agent. If you have any questions concerning these instructions, please call National Customer Service 800.482.1717.