

Barrington®
Attaching Bases to
Conference Tables

Recommended Tools

- Screwdriver

Package Contents

Qty.

NOTE: 14' and 16' tables use four (4) panel bases.
10' and 12' tables use three (3) panel bases.
8' tables use two (2) panel bases.

1 Place top(s) upside down on a smooth, solid surface. Take care to not mar the worksurfaces. On two-piece tables, align the three (3) leveling devices and tighten bolts.

2 On 14' and 16' tables, the mounting pads are pre-attached (Figure A). On 10' and 12' tables, the center mounting pads must be installed. Place mounting pads as shown in (Figure B). The side of the panel base with the two (2) T-nuts should be placed against top panel and the T-nuts positioned toward outside edge of top. Use twelve (12) washers and bolts to attach the center mounting pads.

Figure A

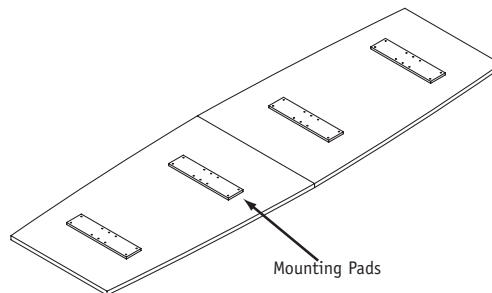

3 Remove plywood pads from the bottom of each pedestal.

Figure B

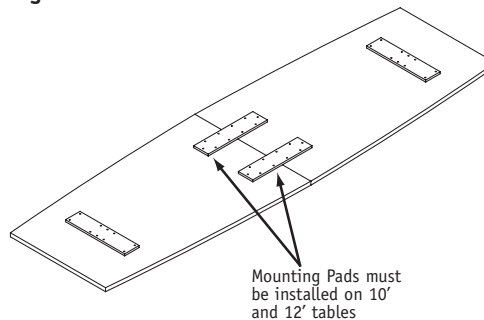

4 On 14' and 16' tables, place panel bases in positions shown in (Figure C). On 10' and 12' tables, the panel bases on each end are attached with six (6) washers and bolts. The center panel base is attached with four (4) washers and bolts. Install the adjustable glides on each panel base (Figure D).

Figure C

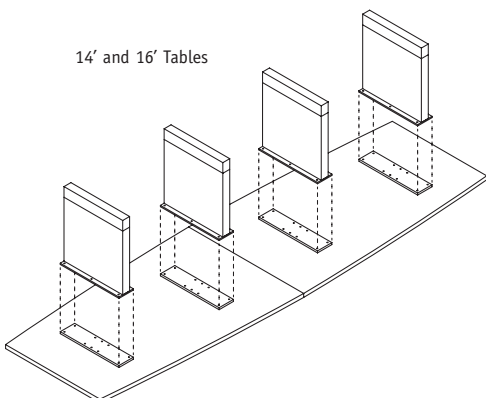
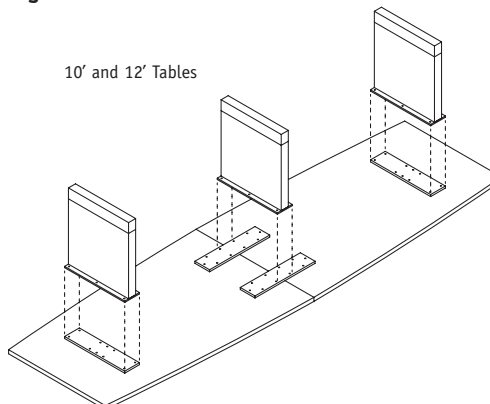

Figure D



NATIONAL
Furniture with Personality®

Telephone 800.482.1717
Fax 812.482.8800
www.nationalonline.com

Part #1847145

Printed in U.S.A.
© 2005 Kimball International, Inc.

Proper product installation, in accordance with these instructions, is the responsibility of the installing agent. If you have any questions concerning these instructions, please call National Customer Service.

CASEGOODS

Assembly Instructions

Barrington® Attaching Bases to Conference Tables

- On 8' 14', and 16' tables, attach each panel base with six (6) provided washers and bolts. On 10' and 12' tables, the panel bases on each end are attached with six(6) washers and bolts. The center panel base is attached with four (4) washers and bolts. Install the adjustable glides on each panel base (Figure E).

Figure D

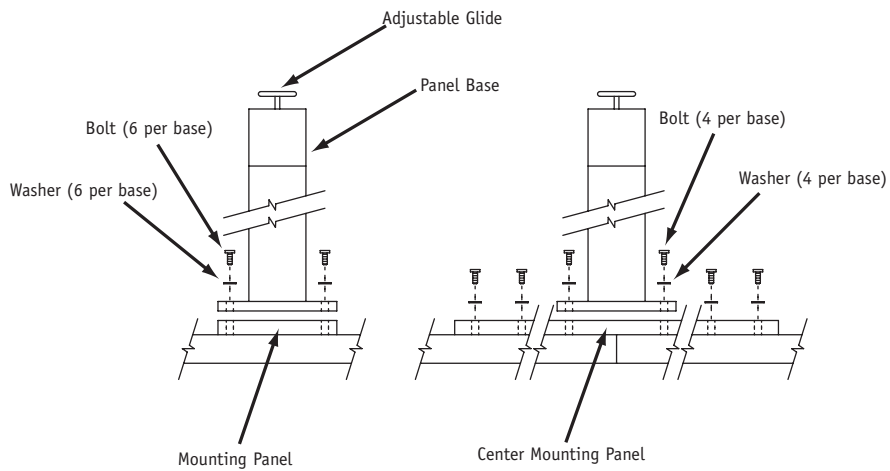

- Carefully turn assembled table upright.

Proper product installation, in accordance with these instructions, is the responsibility of the installing agent. If you have any questions concerning these instructions, please call National Customer Service.