

Assembly Instruction

Casegoods

Florish Bullet with Modesty Panel

Note: It is recommended that two or more people be used in the assembly of this unit.

Note: This instruction explains basic assembly of a bullet/keyhole unit with modesty panel.

1

Place the top worksurface face down on a smooth, hard surface. Take care to not mar the surface. Position cylinder leg mounting plate over the pre-bored holes in the worksurface. Attach cylinder leg using the four (4) #10 x 1" panhead screws provided (Figure A).

Figure A

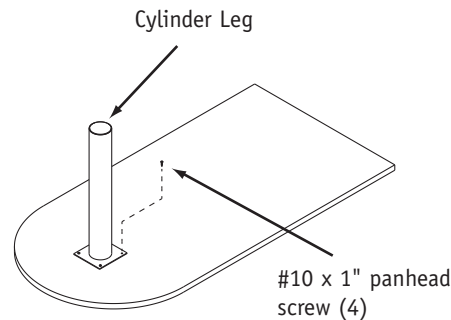

2

Position end panel 1/4" to the back edge of the top worksurface and center along its depth.

Note: Make sure the side of the end panel with the top groove faces to the OUTSIDE of the unit. Attach panel using four (4) L-brackets and 16 #8 x 5/8" panhead screws provided in the approximate locations shown (Figure B).

Figure B

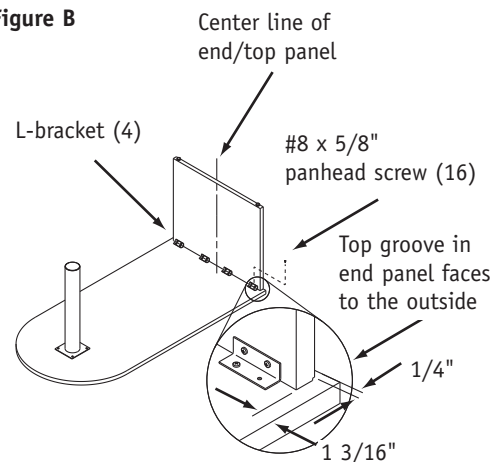

3

Position modesty panel on center between the end panel and the cylinder leg. Attach modesty panel to top worksurface using two (2) L-brackets and eight (8) #8 x 5/8" panhead screws provided, on EACH SIDE, in the approximate locations shown (Figure C)..

Hint: Modesty panel should be flush with the end panel. Use a spacer to create an approximate 1/8" gap between the modesty panel and top worksurface.

Figure C

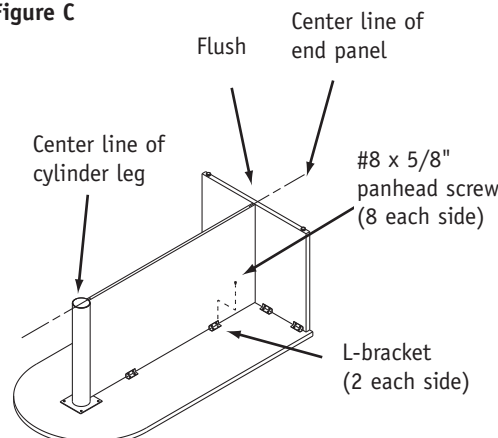

Recommended Tools

- Tape Measure
- Power Drill
- Phillips Screw Bit
- Square
- Level

Package Contents Qty.

BULLET UNIT	
• Top Worksurface	1
• End Panel	1
• Modesty Panel	1
• Cylinder Leg Bracket	1
• L-Brackets	11
• Adjustable Glide	2
• #8 x 5/8" Panhead Screws	46

CYLINDER LEG

• Cylinder Leg	1
• Adjustable Glide	1
• #10 x 1" Panhead Screws	4

NATIONAL Furniture with Personality™

Telephone 800.482.1717
Fax 812.482.8800
www.nationalofficefurniture.com

Part# 2106952
Rev,

Printed in U.S.A.
© 2009 Kimball International, Inc.

Proper product installation, in accordance with these instructions, is the responsibility of the installing agent. If you have any questions concerning these instructions, please call National Customer Service.

Assembly Instructions

Casegoods

Flourish Bullet/Keyhole Unit with Modesty Panel

- 4** Attach the modesty panel to the end panel using three (3) L-brackets and 12 #8 x 5/8" panhead screws provided in the approximate locations shown (Figure D).

Note: These brackets should be attached on the "user side", which is dependent on the specific configuration of the assembled unit.

Figure D

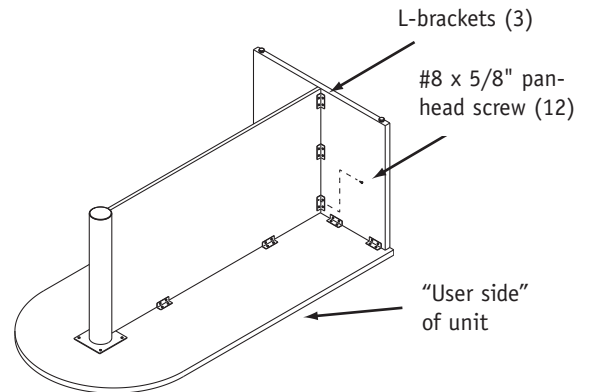

- 5** Slide the cylinder leg bracket over the leg and attach to the modesty panel using two (2) #8 x 5/8" panhead screws provided, one (1) on each side (Figure E).

Figure E

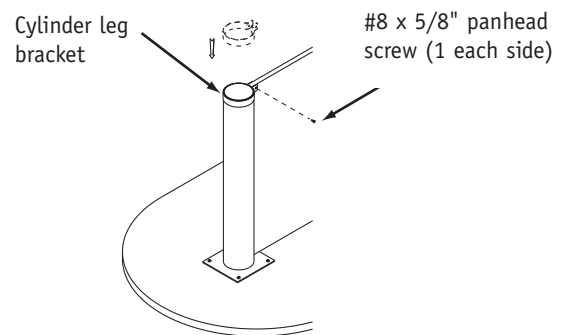

- 6** Carefully turn assembled unit upright and level by extending the two (2) adjustable glides in the end panel and one (1) 4" glide on the cylinder leg (Figure F).

Figure F

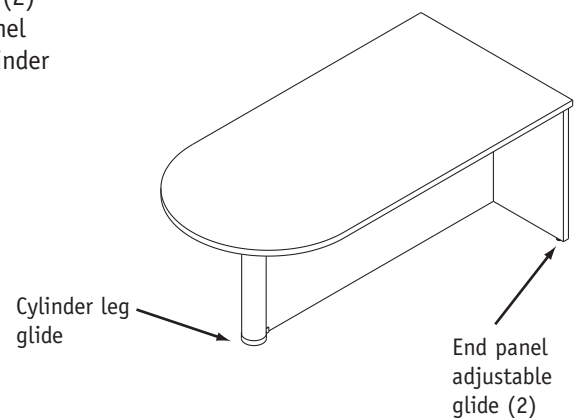

Proper product installation, in accordance with these instructions, is the responsibility of the installing agent. If you have any questions concerning these instructions, please call National Customer Service.